

**AWWA C508  
SWING  
CHECK VALVE**

**Model 8700-G**  
Resilient Seat - 300 psi - Grooved Ends  
Full Waterway

**UNITED**



**MATERIAL LIST**

ITEM NO.	DESCRIPTION	MATERIAL	ASTM SPECIFICATION
1	Body	Ductile Iron	A536 65-45-12
2	Hinge Pin	Stainless Steel	AISI 420
3	Spring	Stainless Steel	AISI 304
4	Spring Washer	Stainless Steel	AISI 304
5	Disc	Ductile Iron	A536 65-45-12
6	Seal Ring	EPDM	-
7	Seat	Bronze	ASTM B62 C83600
8	1/2" NPT Plug	Brass	-

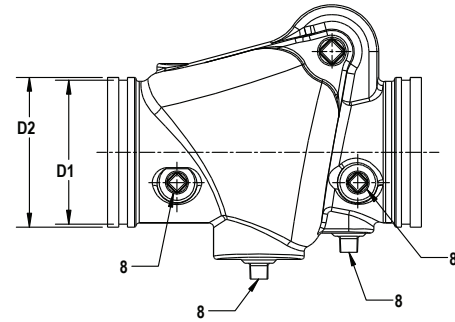
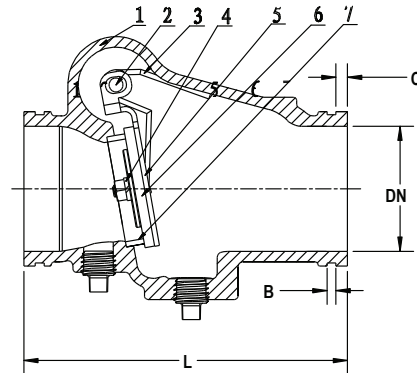

**Description:**

1. Groove dimensions comply with AWWA C606 Standard for steel pipes.
2. Maximum Working Pressure: UL/FM Certified to 300 psi
3. Working Temperature: 0°C to 80°C (32°F to 176°F)
4. Fusion bonded epoxy coated, interior and exterior - AWWA C550

**DIMENSIONAL DATA**

Nominal Size (DN)	Part No.	L	D1	B	C	D2	NPT (8)
2"	8700-G-120	6.75	2.25	0.25	0.62	2.37	1/2
2-1/2"	8700-G-125	7.25	2.75	0.25	0.62	2.87	1/2
3"	8700-G-130	7.75	3.25	0.25	0.62	3.50	1/2
4"	8700-G-140	8.25	4.25	0.38	0.62	4.50	1/2
5"	8700-G-150	9.75	5.5	0.38	0.62	5.50	1/2
6"	8700-G-160	12.75	6.5	0.38	0.62	6.50	1/2
8"	8700-G-180	14.60	8.5	0.5	0.75	8.63	1/2
10"	8700-G-200	18.00	10.5	0.5	0.75	10.75	1/2
12"	8700-G-220	21.00	12.5	0.5	0.75	12.75	1/2

Dimensions in inches  
Note: Design and materials subject to change without notice.



**WARNING:** This product can expose you to chemicals including lead, which is known to the State of California to cause cancer and birth defects or other reproductive harm. For more information go to [www.P65Warnings.ca.gov](http://www.P65Warnings.ca.gov).



**NAPAC - UNITED Distribution Centers**

229 Southbridge Street, Worcester, MA 01608  
Tel: (800) 807-2215 Fax: (800) 807-2214  
[www.napacinc.com](http://www.napacinc.com)

Jacksonville, Florida