

# Seal-Tite Flange Gaskets

## ANSI B16.1 - 125# - ANSI B16.5 - 150#

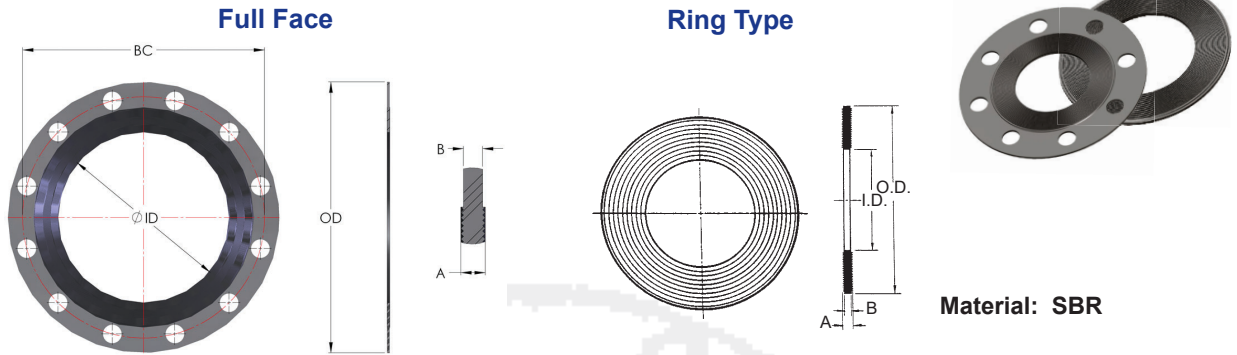

Nominal Size	Part No. (Full Face)	Part No. (Ring)	ID	OD (Full Face)	OD (Ring)	A	B	BC (Full Face)	Box Quantity (Full Face)	Box Quantity (Ring)
2	FFG-050-150	RG-050-100	2.15	6.00	3.90	5/32	1/8	4.75	25	25
2 1/2	FFG-065-175	RG-065-120	2.73	7.00	4.70	5/32	1/8	5.50	25	25
3	FFG-080-188	RG-080-132	3.20	7.50	5.15	5/32	1/8	6.00	25	25
4	FFG-100-210	RG-100-162	3.98	9.00	6.30	5/32	1/8	7.50	25	25
5	FFG-125-250	RG-125-194	5.07	10.00	7.60	5/32	1/8	8.50	25	25
6	FFG-150-275	RG-150-218	6.01	11.00	8.50	5/32	1/8	9.50	25	25
8	FFG-200-340	RG-200-272	8.11	13.50	10.60	5/32	1/8	11.75	25	25
10	FFG-250-400	RG-250-328	10.06	16.00	12.80	5/32	1/8	14.25	25	25
12	FFG-300-475	RG-300-378	12.09	19.00	14.75	5/32	1/8	17.00	10	10
14	FFG-350-525	RG-350-445	14.12	21.00	17.15	5/32	1/8	18.75	10	10
16	FFG-400-588	RG-400-510	16.19	23.50	19.90	5/32	1/8	21.25	10	10
18	FFG-450-625	RG-450-542	18.25	25.00	21.15	5/32	1/8	22.75	10	10
20	FFG-500-688	RG-500-606	20.28	27.50	23.60	5/32	1/8	25.00	10	10
24	FFG-600-800	RG-600-717	24.34	32.00	27.95	5/32	1/8	29.50	10	10

### Bolt Torque Requirements

Size	Working Pressure	
	250 psi WWP min. torque	350 psi WWP min. torque
3"	90 ft. lbs.	110 ft. lbs.
4"	90 ft. lbs.	110 ft. lbs.
6"	90 ft. lbs.	110 ft. lbs.
8"	90 ft. lbs.	130 ft. lbs.
10"	90 ft. lbs.	130 ft. lbs.
12"	90 ft. lbs.	130 ft. lbs.
14"	110 ft. lbs.	-
16"	110 ft. lbs.	-
18"	120 ft. lbs.	-
20"	120 ft. lbs.	-
24"	130 ft. lbs.	-

**Notes:**

The Seal-Tite gasket makes contact on the machined pipe surfaces creating a positive seal between the pipe ends on ductile iron fabricated pipe, eliminating possible leakage at the threads.

**Material Standard:** SBR (styrene-butadiene rubber )  
- ASTM D3186-97

**Reference Standard:**

**Full Face** - Fits ANSI B16.1 Class 125/150 Flanges

**Ring Type** - Fits ANSI B16.1 / Class ANSI B16.5  
Class 125/150/250/300 Flanges

**Temperature Rating:**

-20°F or +180°F



**WARNING:** This product can expose you to chemicals including lead, which is known to the State of California to cause cancer and birth defects or other reproductive harm. For more information go to [www.P65Warnings.ca.gov](http://www.P65Warnings.ca.gov).



**NAPAC - UNITED Distribution Centers**

229 Southbridge Street, Worcester, MA 01608  
Tel: (800) 807-2215 Fax: (800) 807-2214  
[www.napacinc.com](http://www.napacinc.com)

Jacksonville, Florida