

# LUG WAFER BUTTERFLY VALVE

# Model 2400-L Manually Gear Operated with Tamper Switch



### Description:

1. Design Standard: MSS-SP-67 & API 609
2. EPDM Encapsulated ductile iron disc for bubble-tight shut off
3. Flag type position indicator
4. Low torque operation
5. High cycle life
6. Built-in supervisory switch
7. Top flange to ISO 5211/1
8. Flange connection to ANSI B16.1 Class 125/ANSI B16.5 Class 150
9. Working Pressure: 2"~8": 300 psi, 10" & 12": 250 psi
10. Working Temperature: 33°F to 176°F (0°C to 80°C)
11. Fusion bonded epoxy powder coated to AWWA C550.
12. UL Listed / FM Approved for indoor or outdoor use.



### DIMENSIONS

Nominal Size	Part No.	A	B	L	C	H1	H	ØD	N-M
2"	2400-L-120	5.52	2.56	4.82	1.69	5.00	7.96	4.75	4 x 5/8"
2-1/2"	2400-L-125	6.02	2.80	4.82	1.81	5.00	7.96	5.50	4 x 5/8"
3"	2400-L-130	6.20	3.19	4.82	1.81	5.00	7.96	6.00	4 x 5/8"
4"	2400-L-140	6.93	3.74	4.82	2.05	5.00	7.96	7.50	8 x 5/8"
5"	2400-L-150	7.52	4.37	4.82	2.20	5.00	7.96	8.50	8 x 3/4"
6"	2400-L-160	7.97	5.24	4.82	2.20	5.00	7.96	9.50	8 x 3/4"
8"	2400-L-180	9.59	6.46	4.82	2.36	7.28	10.79	11.75	8 x 3/4"
10"	2400-L-200	10.75	7.72	4.82	2.68	7.28	10.79	14.25	12 x 7/8"
12"	2400-L-220	12.24	8.90	5.20	3.07	7.97	11.56	17.00	12 x 7/8"

Design and materials are subject to change without notice.

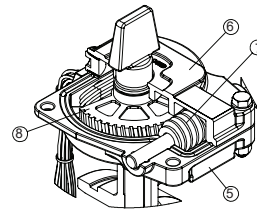
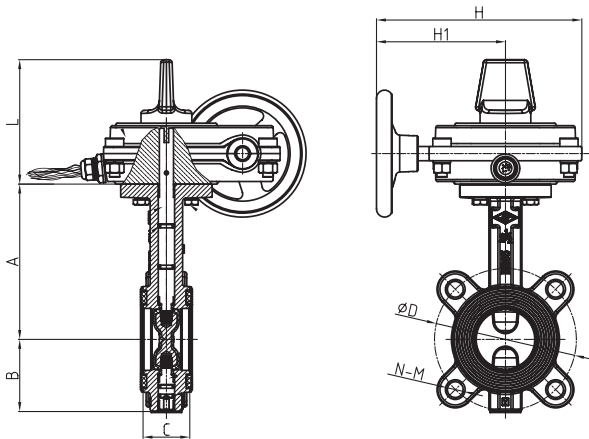

### LIST OF MATERIALS

	Description	Material/Specification
Valve	Body	Ductile Iron, ASTM A536 65-45-12
	Stem Shaft	Stainless Steel, AISI 431
	Disc	Ductile Iron, EPDM encapsulated
	Stem O-rings	EPDM
	End Face Seal	EPDM
Gear Operator	Housing	Ductile Iron, ASTM A536 65-45-12
	Cover	Cast Iron, ASTM A126 Class B
	Worm	Carbon Steel, AISI 1045
	Worm Gear	Ductile Iron, ASTM A536 65-45-12
	Handwheel	Ductile Iron ASTM A536 65-45-12

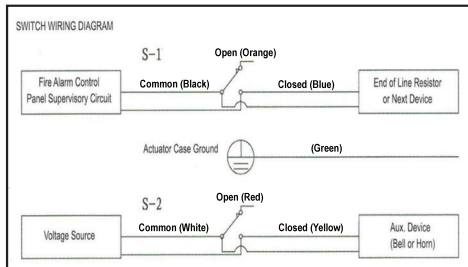

**WARNING:** This product can expose you to chemicals including lead, which is known to the State of California to cause cancer and birth defects or other reproductive harm. For more information go to [www.P65Warnings.ca.gov](http://www.P65Warnings.ca.gov).



## NAPAC - UNITED Distribution Centers

229 Southbridge Street, Worcester, MA 01608  
Tel: (800) 807-2215 Fax: (800) 807-2214  
[www.napacinc.com](http://www.napacinc.com)

Jacksonville, Florida