

AWWA C508 SWING CHECK VALVE

Model 7700 Full Waterway

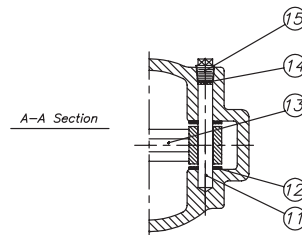
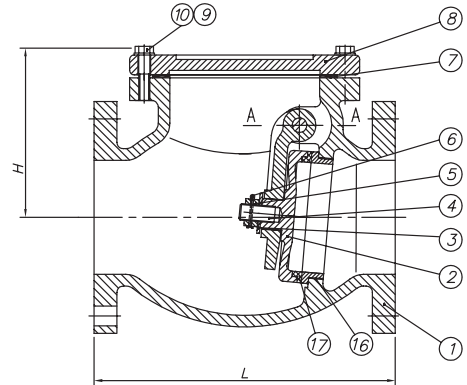

DESCRIPTION:

1. Flange drilling to ANSI 125/150. Metric PN10/PN16 drilling is available upon request
2. End to End Dimensions (Laying Length) to AWWA C-508 Standard for Full Waterway Swing Check Valves
3. Maximum working pressure-temperature: 200 psi
4. Suitable for Water / Sludge / Sewage service
5. Fusion Bonded Epoxy Coated Interior and Exterior to AWWA C550. Powder Certified to NSF-61
6. Installed with standard flange accessories (AWWA C110)
7. Meets all requirements of MSS SP-71

MATERIAL LIST

Item No.	Description	Material	Item No.	Description	Material
1	Body	C.I. ASTM A126, Class B	10	Washer	Stainless Steel AISI 304
2	Disc	C.I. ASTM A126, Class B	11	Stem	Stainless Steel AISI 304
3	Washer	Stainless Steel AISI 304	12	Washer	PTFE
4	Bolt	Stainless Steel AISI 304	13	Hanger	C.I. ASTM A126, Class B
5	Nut	Stainless Steel AISI 304	14	Gasket	Rubber D2000, NBR
6	Cotter Pin	Stainless Steel AISI 304	15	Plug	Brass, ASTM B16 C36000
7	Gasket	Graphite	16	Body Trim	Bronze, ASTM B62 C83600
8	Cover	C.I. ASTM A126, Class B	17	Disc Trim	Rubber D2000, NBR
9	Bolt	Stainless Steel AISI 304	-	-	-

Design and materials subject to change without notice.

DIMENSIONAL DATA

Dimensions in inches

Size	2"	2.5"	3"	4"	5"	6"	8"	10"	12"	14"	16"	18"	20"	24"
Part No.	7700-120	7700-125	7700-130	7700-140	7700-150	7700-160	7700-180	7700-200	7700-220	7700-240	7700-260	7700-280	7700-300	7700-340
L	8	8.5	9.5	11.5	13	14	19.5	24.5	27.5	31	36	38	40	48.3
H	4.76	5.31	5.55	6.61	7.16	8.46	10.51	12	13.50	17.71	20.46	21.64	23.22	26.76



WARNING: This product can expose you to chemicals including lead, which is known to the State of California to cause cancer and birth defects or other reproductive harm. For more information go to www.P65Warnings.ca.gov.



Napac, Inc.
120 Front Street, Suite 820, Worcester, MA 01608
TEL. 800-807-2215
Website: www.napacinc.com