

AWWA C508 SWING CHECK VALVE

Model 7700F (w/Lever and Wgt. or Lever & Spring) Full Waterway

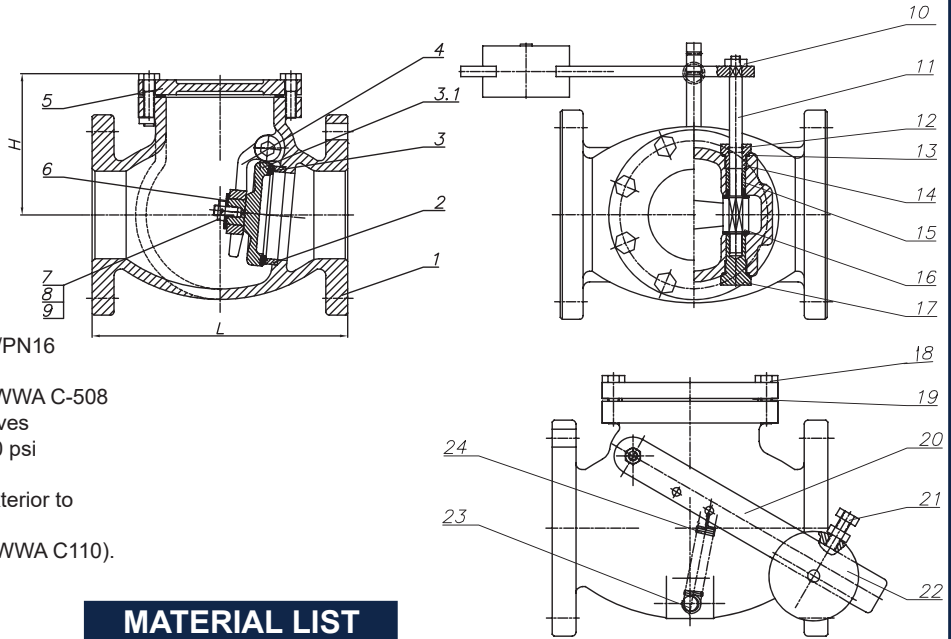

Series 7700-LW (with lever & weight)
Series 7700-LS (with lever & spring)



DESCRIPTION:

1. Flange drilling to ANSI 125/150. Metric PN10/PN16 drilling is available upon request
2. End to End Dimensions (Laying Length) to AWWA C-508 Standard for Full Waterway Swing Check Valves
3. Maximum working pressure-temperature: 200 psi
4. Suitable for Water / Sludge / Sewage service
5. Fusion Bonded Epoxy Coated Interior and Exterior to AWWA C550. Powder Certified to NSF-61
6. Installed with standard flange accessories (AWWA C110).
7. Meets all requirements of MSS SP-71

MATERIAL LIST

Item No.	Description	Material	Item No.	Description	Material
1	Body	C.I. ASTM A126, Class B	13	Spacer	PTFE
2	Body Trim	Bronze, C83600	14	Gland	Brass, C36000
3.1	Nut	Stainless Steel AISI 304	15	Bushing	Brass, C36000
3	Disc Trim	Rubber, NBR	16	Spacer	PTFE
4	Hanger	C.I. ASTM A126, Class B	17	Plug	Brass, C36000
5	Cover	C.I. ASTM A126, Class B	18	Bolt	Stainless Steel AISI 304
6	Disc Spacer	Carbon Steel	19	Gasket	Graphite
7	Hanger Pin	Stainless Steel AISI 304	20	Lever	Carbon Steel, AISI 1020
8	Hanger Nut	Stainless Steel AISI 304	21	Bolt	Stainless Steel AISI 304
9	Cotter Pin	Stainless Steel AISI 304	22	Weight	C.I. ASTM A126, Class B
10	Stem Nut	Stainless Steel AISI 304	23	Weight Pin	Carbon Steel
11	Stem	Stainless Steel AISI 304	24	Spring	Carbon Steel
12	O-Ring	Rubber, NBR	-	-	-

Design and materials subject to change without notice.

DIMENSIONAL DATA

Dimensions in inches

Size	2"	2.5"	3"	4"	5"	6"	8"	10"	12"	14"	16"	18"	20"	24"
Part No.	7700-F-120-*	7700-F-125-*	7700-F-130-*	7700-F-140-*	7700-F-150-*	7700-F-160-*	7700-F-180-*	7700-F-200-*	7700-F-220-*	7700-F-240-*	7700-F-260-*	7700-F-280-*	7700-F-300-*	7700-F-340-*
L	8	8.5	9.5	11.5	13	14	19.5	24.5	27.5	31	36	38	40	48
H	4.76	5.31	5.55	6.61	7.16	8.46	10.51	12	13.50	18	20	22	23	27

*Indicate: LW - with lever & weight
LS - with lever & spring



WARNING: This product can expose you to chemicals including lead, which is known to the State of California to cause cancer and birth defects or other reproductive harm. For more information go to www.P65Warnings.ca.gov.



NAPAC
A PUPCO Brand

Napac, Inc.
120 Front Street, Suite 820, Worcester, MA 01608
TEL. 800-807-2215
Website: www.napacinc.com