

Wall Type Indicator Post Model 5500

UNITED BRAND



MATERIAL LIST



1	Eye Bolt	Carbon Steel ASTM A307B
2	Hex Nut	Carbon Steel ASTM A307B
3	Washer	Carbon Steel ASTM A570 Gr 33
4	Handwheel	Ductile Iron ASTM A536 Gr 65-45-12
5	Hex Cap Screw	Carbon Steel ASTM A307B
6	Square Nut	Carbon Steel ASTM A307B
7	Snap Ring	Stainless Steel AISI 1066
8	Cover	Cast Iron ASTM A126 Class B
9	Operating Nut	Bronze ASTM B62 C83600
		Stainless Steel AISI 3040
10	Target Carrier Nut	Bronze ASTM B62 C83600
		Stainless Steel AISI 3040
11	Window Glass	Plexiglass
12	Gasket	PTFE
13	Hex Nut	Carbon Steel ASTM A307B
14	Plug	Malleable Iron
15	Target	Cast Aluminum
16	Hex Cap Screw	Carbon Steel ASTM A307B
17	Hex Nut	Carbon Steel ASTM A307B
18	Body	Cast Iron ASTM A126 Class B
19	Stem	Carbon Steel AISI 1045
20	Crane Coupling	Ductile Iron ASTM A536 Gr 65-45-12
21	Cotter Pin	Stainless Steel AISI 3040

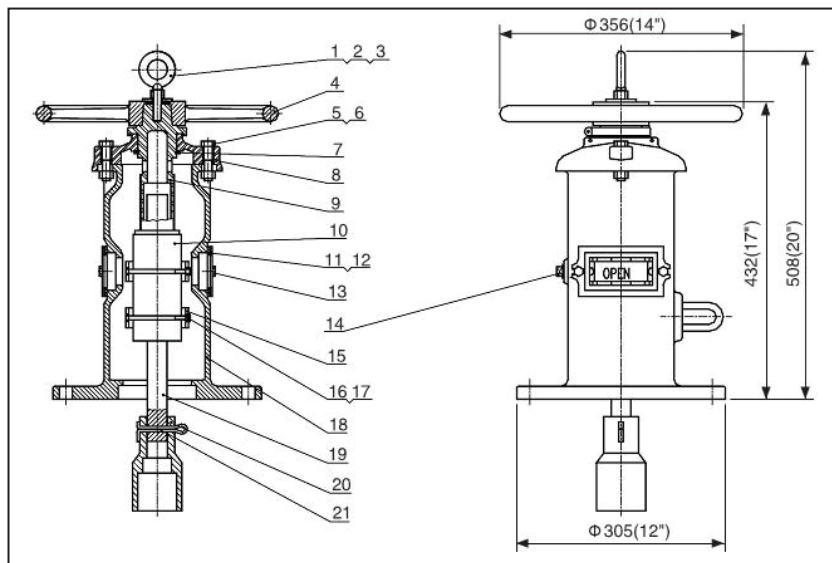

Specifications

- Indicates if valve is in open or shut position
- Used to operate a valve installed behind a wall
- With a 12" OD post flange to mount on a wall
- Operated by handwheel
- Can be supplied to open Left or Right
- FM and UL Approved

Field Adjustment

- Remove the Top Section from the top of the Indicator Post assembly.
- Reattach the Top Section to the top of the Indicator Post assembly.
- Set the "OPEN" and "SHUT" targets for the appropriate valve size



NAPAC, Inc.

229 Southbridge Street, Worcester, MA 01608 U.S.A.

Tel: (800) 807-2215 • Fax: (800) 807-2214 www.napacinc.com sales@napacinc.com