

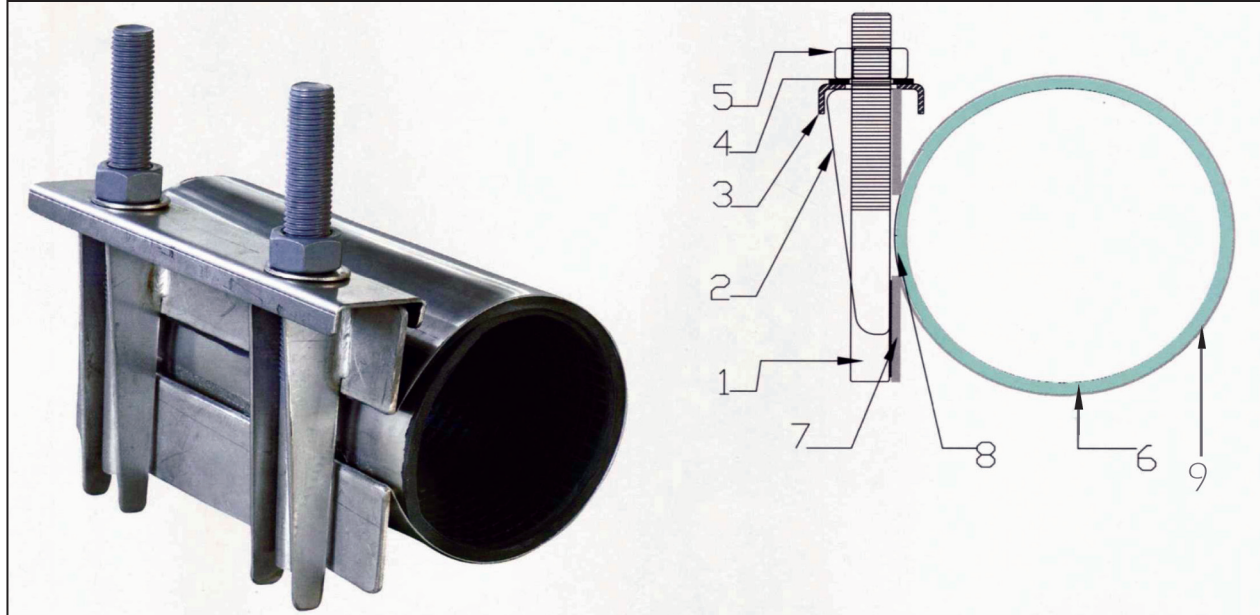

NAPAC INC.

Stainless Steel Repair Clamps

Cost Effective - Long Lasting Repair on a Variety of Types of Pipe!



Temperature Range

- 40° F - 212° F

MATERIALS

No.	Part Name	Material
1	Bolt	ASTM A240 type 304 Stainless Steel with Teflon coating
2	Lug Plate	ASTM A240 Type 304 Stainless Steel
3	Lifter Bar	ASTM A240 Type 304 Heavy Guage Stainless Steel
4	Washer	Type 304 Stainless Steel or Nylon
5	Nut	ASTM A240 Type 304 Stainless Steel - Anit-galling
6	Gridded Gasket	EPDM suitable for potable water and wastewater
7	Side Bar	ASTM A240 Type 304 Heavy Guage Stainless Steel
8	Armor	ASTM A240 Type 304 Stainless Steel Integrally Molded into the gasket to ensure even compression on against pipe
9	Band	Type 304 Stainless Steel offering high strength, flexibility, & resistance to corrossion on underground pipelines

Bolt Number According to Length

Length (mm)	150	191/200	300
Bolt No.	2	3	4

Size	OD Range	Length	Bolt
4"	4.53" - 5.04"	8"	5/8"
		12"	
6"	6.61" - 7.17"	8"	5/8"
		12"	
8"	8.86" - 9.45"	8"	5/8"
		12"	
10"	10.63" - 11.34"	12"	5/8"
12"	13.10" - 13.50"	12"	5/8"

All Welds are Fully Passivated for Corrossion Resistance