

Seal-Tite Flange Gaskets

ANSI B16.1 - 125# • ANSI B16.5 - 150#

**UNITED
BRAND**

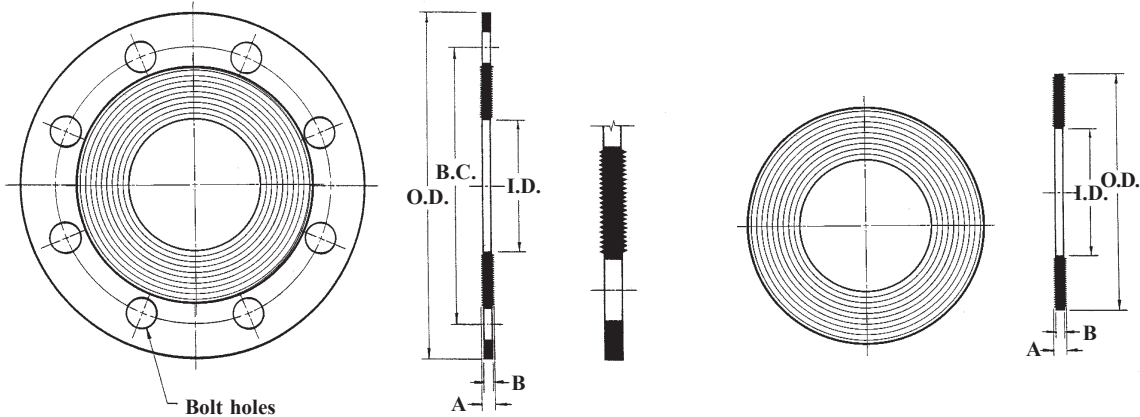

FULL FACE

RING TYPE

- Low Torque Sealing
- Molded one piece gasket
- SBR material -20°F ~ +180°F
- Recommended for water and wastewater

DIMENSIONS IN INCHES

Nominal Size	Part No. (Full Face)	Part No. (Ring Type)	ID	OD (Full Face)	OD (Ring Type)	A	B	BC (Full Face)	No. of Bolts Holes (Full Face)	Size of Bolt Holes (Full Face)
2	FFG-050-150	RG-050-100	2.15	6.00	3.90	.16	.12	4.75	4	.75
2 1/2	FFG-065-175	RG-065-120	2.73	7.00	4.70	.16	.12	5.50	4	.75
3	FFG-080-188	RG-080-132	3.20	7.50	5.15	.16	.12	6.00	4	.75
4	FFG-100-210	RG-100-162	3.98	8.50	6.30	.16	.12	7.50	8	.75
5	FFG-125-250	RG-125-194	5.07	10.00	7.60	.16	.12	8.50	8	.88
6	FFG-150-275	RG-150-218	6.01	11.00	8.50	.16	.12	9.50	8	.88
8	FFG-200-340	RG-200-272	8.11	13.50	10.60	.16	.12	11.75	8	.88
10	FFG-250-400	RG-250-328	10.06	16.00	12.80	.16	.12	14.25	12	1.00
12	FFG-300-475	RG-300-378	12.09	19.00	14.75	.16	.12	17.00	12	1.00
14	FFG-350-525	RG-350-445	14.12	21.00	17.15	.16	.12	18.75	12	1.13
16	FFG-400-588	RG-400-510	16.19	23.50	19.90	.16	.12	21.25	16	1.13
18	FFG-450-625	RG-450-542	18.25	25.00	21.15	.16	.12	22.75	16	1.25
20	FFG-500-688	RG-500-606	20.28	27.50	23.60	.16	.12	25.00	20	1.25
24	FFG-600-800	RG-600-717	24.34	32.00	27.95	.16	.12	29.50	20	1.38
30	FFG-750-985	RG-750-875	30.98	38.75	34.50	.18	.14	36.00	28	1.38
36	FFG-900-1165	RG-900-1040	37.14	46.00	41.00	.18	.14	42.75	32	1.63

NAPAC, Inc.

229 Southbridge Street, Worcester, MA 01608 U.S.A.

Tel: (800) 807-2215 • Fax: (800) 807-2214

Flanged Pipe Assembly with *Seal-Tite* Gaskets

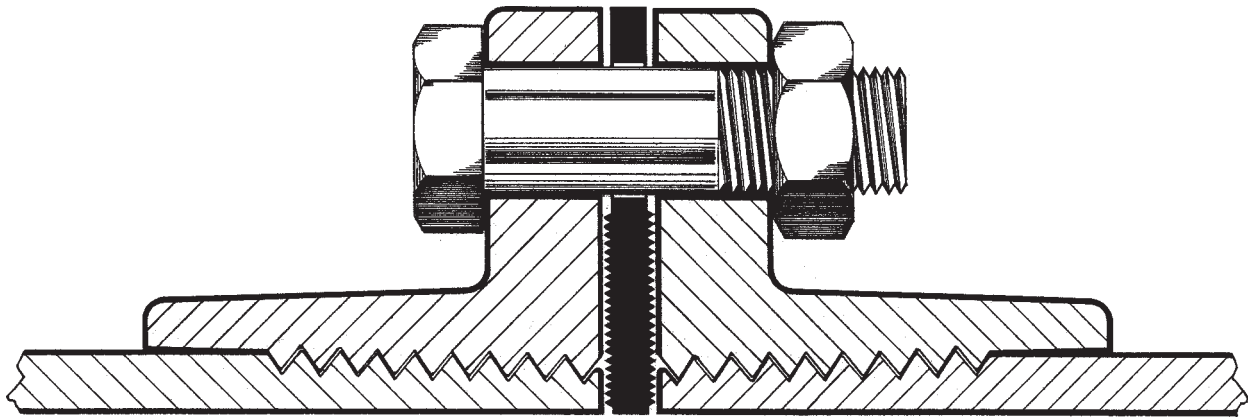

Seal-Tite gasket makes contact on the machined pipe surfaces creating a positive seal between the pipe ends on ductile iron fabricated pipe, eliminating possible leakage at the threads.

Assembly Instructions:

All flange faces, bolts, nuts, and gaskets should be free of dirt, grease, or other foreign matter.

The ring gasket will fit just inside the bolt holes. We recommend gluing the gasket to the face of one of the flanges to ensure correct alignment and to ease in the installation.

Bolts should be torqued to this minimum torque requirement shown in the table, in several steps, alternating with opposite bolts 180° apart.

Bolt Torque Requirements

Size	Working Pressure	
	250 psi WWP min. torque	350 psi WWP min. torque
3"	90 ft. lbs.	110 ft. lbs.
4"	90 ft. lbs.	110 ft. lbs.
6"	90 ft. lbs.	110 ft. lbs.
8"	90 ft. lbs.	130 ft. lbs.
10"	90 ft. lbs.	130 ft. lbs.
12"	90 ft. lbs.	130 ft. lbs.
14"	110 ft. lbs.	-
16"	110 ft. lbs.	-
18"	120 ft. lbs.	-
20"	120 ft. lbs.	-
24"	130 ft. lbs.	-
30"	140 ft. lbs.	-
36"	160 ft. lbs.	-

Note: Design subject to change without notice.

NAPAC, Inc.

229 Southbridge Street, Worcester, MA 01608 U.S.A.

Tel: (800) 807-2215 • Fax: (800) 807-2214