

# Ultra-Lok Gland Model 6500

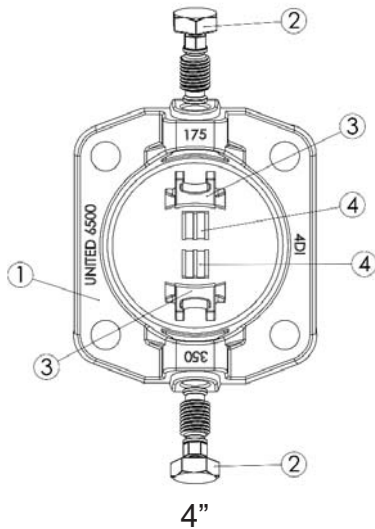

4"

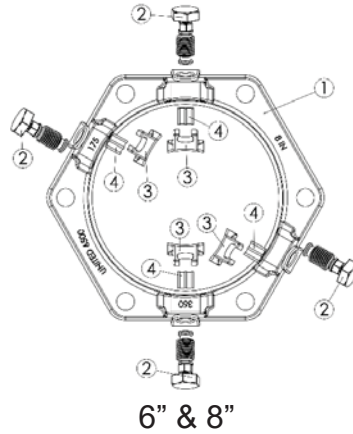

6" & 8"

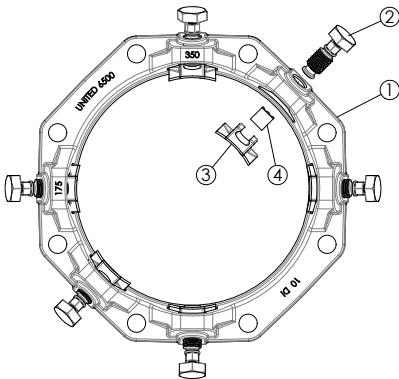

10" & 12"

## DIMENSIONAL DATA

Nominal Size	Part No.	Pipe OD	Pressure Rating	Approx. Wgt.
4"	6500-04-D	4.80	350 psi	8
6"	6500-06-D	6.90	350 psi	12
8"	6500-08-D	9.05	350 psi	16
10"	6500-10-D	11.10	350 psi	24
12"	6500-12-D	13.20	350 psi	32

## MATERIAL LIST

No.	Description	Material
1	Gland	Ductile Iron, ASTM A536, 65-45-12
2	Torque-off Bolt	Ductile Iron, ASTM A536, 65-45-12
3	Wedge	Ductile Iron, ASTM A536, 65-45-12
4	Rubber Spacer	Rubber

## Description:

1. High Strength ductile iron mechanical joint glad con forming to ANSI /AWWA C111/A21.11
2. Multiples of hardened ductile iron restraint wedges
3. Wedges have breakaway heads to ensure proper torque values
4. For use on water and wastewater ductile pipelines to ANSI/AWWA C151/A21.51
5. Rated @ 350 psi with a 2 to 1 safety factor



**WARNING:** This product can expose you to chemicals including lead, which is known to the State of California to cause cancer and birth defects or other reproductive harm. For more information go to [www.P65Warnings.ca.gov](http://www.P65Warnings.ca.gov).



**NAPAC - UNITED Distribution Centers**

229 Southbridge Street, Worcester, MA 01608  
Tel: (800) 807-2215 Fax: (800) 807-2214  
[www.napacinc.com](http://www.napacinc.com)

Jacksonville, Florida