

# LUG WAFER BUTTERFLY VALVE

# Model 2400-L Manually Gear Operated with Tamper Switch



### Description:

1. Design Standard: MSS-SP-67 & API 609
2. EPDM Encapsulated ductile iron disc for bubble-tight shut off
3. Flag type position indicator
4. Low torque operation
5. High cycle life
6. Built-in supervisory switch
7. Top flange to ISO 5211/1
8. Flange connection to ANSI B16.1 Class 125/ANSI B16.5 Class 150
9. Working Pressure: 2"-8": 300 psi, 10" & 12": 250 psi
10. Working Temperature: 33°F to 176°F (0°C to 80°C)
11. Fusion bonded epoxy powder coated to AWWA C550.
12. UL Listed / FM Approved for indoor or outdoor use.



### DIMENSIONS

Nominal Size	Part No.	A	B	L	C	H1	H	ØD	N-M
2"	2400-L-120	5.52	2.56	4.82	1.69	5.00	7.96	4.75	4 x 5/8"
2-1/2"	2400-L-125	6.02	2.80	4.82	1.81	5.00	7.96	5.50	4 x 5/8"
3"	2400-L-130	6.20	3.19	4.82	1.81	5.00	7.96	6.00	4 x 5/8"
4"	2400-L-140	6.93	3.74	4.82	2.05	5.00	7.96	7.50	8 x 5/8"
5"	2400-L-150	7.52	4.37	4.82	2.20	5.00	7.96	8.50	8 x 3/4"
6"	2400-L-160	7.97	5.24	4.82	2.20	5.00	7.96	9.50	8 x 3/4"
8"	2400-L-180	9.59	6.46	4.82	2.36	7.28	10.24	11.75	8 x 3/4"
10"	2400-L-200	10.75	7.72	4.82	2.68	7.28	10.24	14.25	12 x 7/8"
12"	2400-L-220	12.24	8.90	5.20	3.07	7.97	11.71	17.00	12 x 7/8"

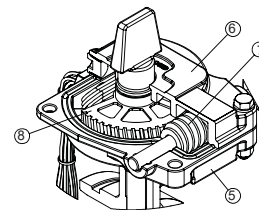
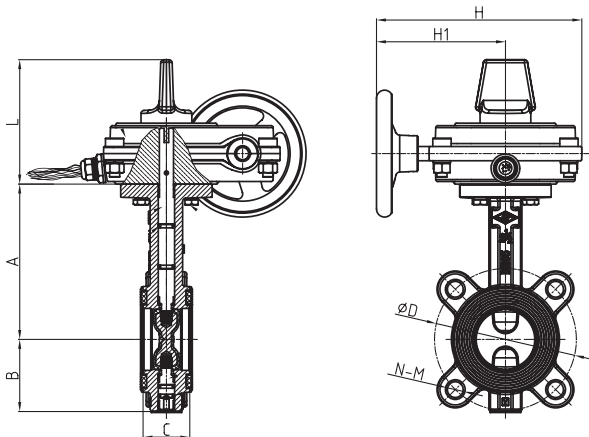

### LIST OF MATERIALS

	Description	Material/Specification
Valve	Body	Ductile Iron, ASTM A536 65-45-12
	Stem Shaft	Stainless Steel, AISI 431
	Disc	Ductile Iron, EPDM encapsulated
	Stem O-rings	EPDM
	End Face Seal	EPDM
Gear Operator	Housing	Ductile Iron, ASTM A536 65-45-12
	Cover	Cast Iron, ASTM A126 Class B
	Worm	Carbon Steel, AISI 1045
	Worm Gear	Ductile Iron, ASTM A536 65-45-12
	Handwheel	Ductile Iron ASTM A536 65-45-12

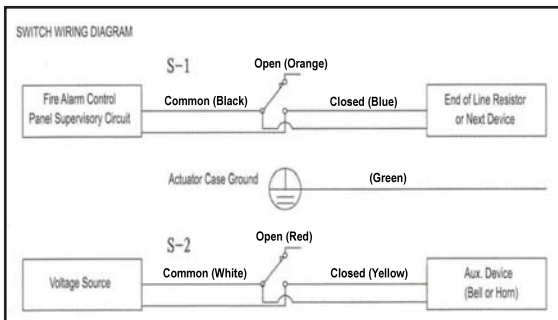

Design and materials are subject to change without notice.



## NAPAC - UNITED Distribution Centers

229 Southbridge Street, Worcester, MA 01608  
Tel: (800) 807-2215 Fax: (800) 807-2214  
www.napacinc.com

Jacksonville, Florida