

Standard Port Brass Ball Valve Model 1300T & 1300S 400 WOG

UNITED BRAND



ITEM NO.	DESCRIPTION	MATERIAL
1	Body	Cast Brass
2	Bonnet	Cast Brass
3	Ball	Chrome Plated Forged Brass
4	Stem	Extruded Brass
5	Seat	Teflon
6	Packing	Teflon
7	Packing Gland	Extruded Brass
8	Hex Nut	Extruded Brass
9	Lever Handle	Steel w/Vinyl Cover

- Meets NSF61 Section 9 Requirement for low lead content.
- Blowout proof stem.

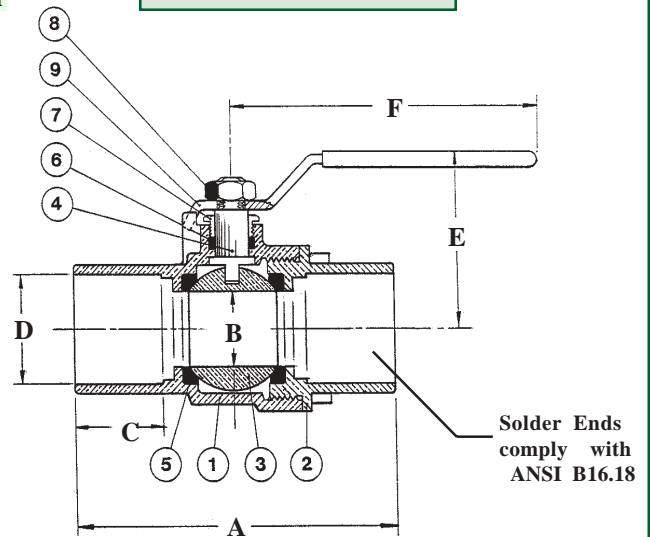
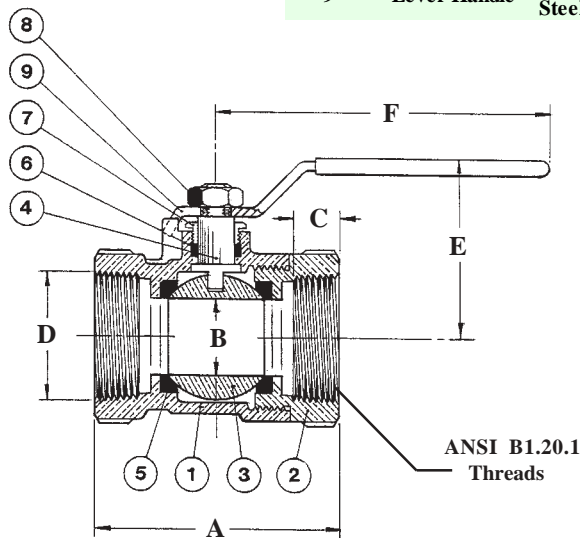

DIMENSIONS IN INCHES • WEIGHT IN POUNDS

Threaded

C x C

Nominal Size	Part No.	A	B	C	D	E	F	Est. Weight
1/4	1300-T-03	1.62	0.30	0.39	1/4-18 NPT	1.33	3.20	0.45
3/8	1300-T-04	1.70	0.40	0.41	3/8-18 NPT	1.40	3.20	0.50
1/2	1300-T-05	1.95	0.40	0.51	1/2-14 NPT	1.48	3.20	0.60
3/4	1300-T-07	2.25	0.60	0.55	3/4-14 NPT	1.68	3.20	0.90
1	1300-T-08	2.65	0.80	0.68	1-11.5 NPT	2.42	5.20	1.55
1 1/4	1300-T-09	2.95	1.00	0.70	1 1/4-11.5 NPT	2.54	5.20	2.05
1 1/2	1300-T-10	3.35	1.25	0.74	1 1/2-11.5 NPT	2.81	5.55	2.80
2	1300-T-11	3.70	1.55	0.76	2-11.5 NPT	3.04	5.55	3.70
2 1/2	1300-T-12	4.95	1.90	1.17	2 1/2-8 NPT	3.86	8.20	7.65
3	1300-T-13	5.40	2.35	1.19	3-8 NPT	4.17	9.50	11.50
4	1300-T-14	6.60	2.90	1.29	4-8 NPT	4.68	9.50	19.00

Nominal Size	Part No.	A	B	C	D	E	F	Est. Weight
1/2	1300-S-05	2.05	0.40	0.50	0.63	1.50	3.20	0.50
3/4	1300-S-07	2.65	0.60	0.75	0.88	1.70	3.20	0.75
1	1300-S-08	3.50	0.80	0.91	1.13	2.50	5.20	1.50
1 1/4	1300-S-09	3.85	1.00	0.97	1.38	2.55	5.20	2.15
1 1/2	1300-S-10	4.25	1.25	1.09	1.63	2.80	5.55	2.70
2	1300-S-11	4.75	1.55	1.34	2.13	3.04	5.55	3.70

Note: Design subject to change without notice.

NAPAC, Inc.

229 Southbridge Street, Worcester, MA 01608 U.S.A.

Tel: (800) 807-2215 • Fax: (800) 807-2214