

AWWA C509

# Resilient Seat GATE VALVE

**MODEL 2000FF, 3" - 12"**  
**Flanged Ends to ANSI B16.1 (125 lb.)**  
**200 psi Non-Shock Cold Water at 175°F**  
**Resilient Wedge - Non Rising Stem**

# UNITED BRAND



### DESCRIPTION:

1. Conforms to AWWA C509.
2. Epoxy coated inside and outside to AWWA C550.
3. 2" square cap or optional wheel handle at customer's request.

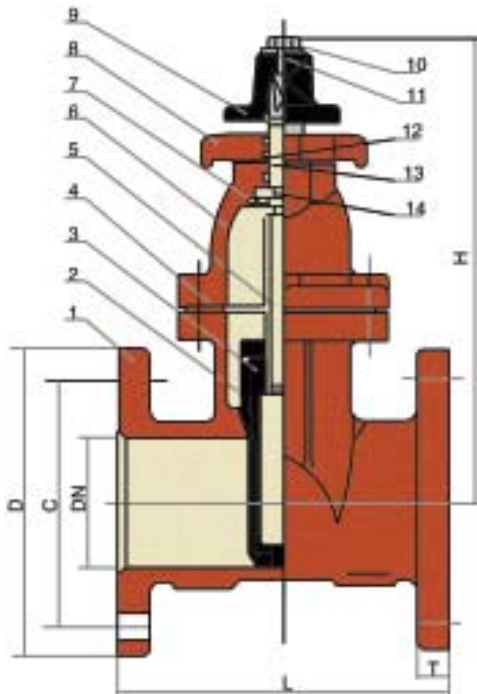

### MATERIAL LIST

ITEM NO.	DESCRIPTION	MATERIAL	SPECIFICATION
1	Body	Cast Iron	A126 Class B
2	Disc	Cast Iron (Buna) Encapsulated	A126 Class B
3	Stem Nut	Bronze	B62
4	Bonnet Gasket	Buna-N	ASTM D2000
5	Stem	Stainless Steel	Series 400
6	Bonnett	Cast Iron	A126 Class B
7	C-Clip	Mn Steel	C1065
8	Stuffing Box	Cast Iron	A126 Class B
9	Op. Nut	Cast Iron	A126 Class B
10	Op. Nut Bolt	Stainless Steel	304
11	Washer	Stainless Steel	304
12	O-Ring	Buna-N	ASTM D2000
13	Flat Washer	Buna-N	ASTM D2000
14	Split Ring	Bronze	B62
15	Hand Wheel	Cast Iron	A126 Class B
16	Stuffing Box Bolt	Stainless Steel	304
17	Bonnet Bolt	Stainless Steel	304

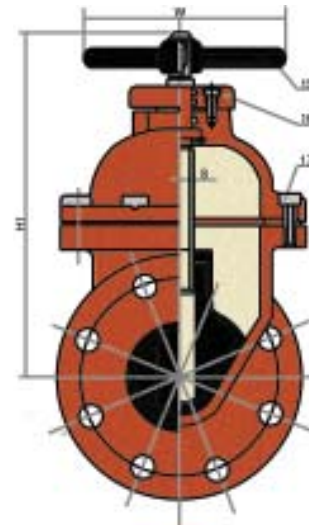

Design and materials are subject to change without notice.

### DIMENSIONAL DATA

DN Nominal Size	Part No.	L	D	C	T	Bolt Holes No.	Size	S	W	H1	H	Wt.
3	2000FF-130	8.00	7.50	6.00	3/4	4	0.75	1.10	7.87	12.52	13.31	53
4	2000FF-140	9.00	9.00	7.50	15/16	8	0.75	1.10	10.24	13.86	14.65	83
6	2000FF-160	10.50	11.00	9.50	1	8	0.88	1.26	12.60	17.40	18.19	139
8	2000FF-180	11.50	13.50	11.75	1-1/8	8	0.88	1.26	14.17	20.87	21.65	232
10	2000FF-200	13.00	16.00	14.25	1-3/16	12	1.00	1.42	16.00	26.00	26.38	365
12	2000FF-220	14.00	19.00	17.00	1-1/4	12	1.00	1.42	16.00	28.66	29.47	517

Form No. NU0006FF

Dimensions in inches - Weight in lbs.

**NAPAC, Inc.**

**229 Southbridge Street, Worcester, MA 01608**

**Tel: (800) 807-2215**

**Fax: (800) 807-2214**