

# Gas Ball Valve

**UNITED  
BRAND**

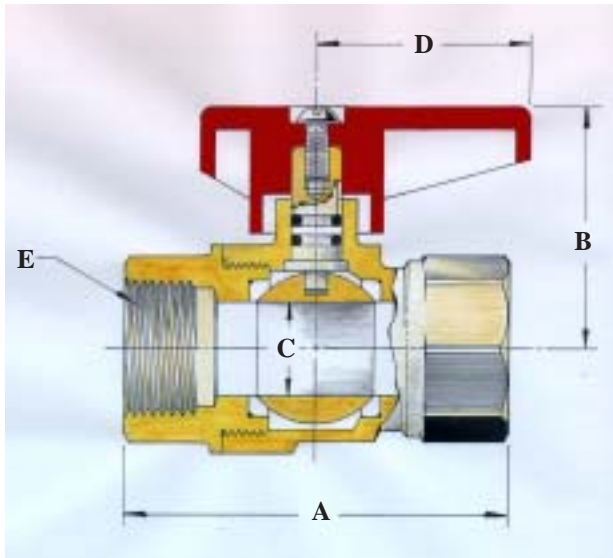

| ITEM NO. | PART    | MATERIAL         |
|----------|---------|------------------|
| 1        | BODY    | BRASS            |
| 2        | BONNET  | BRASS            |
| 3        | BALL    | HARD C.P. BRASS  |
| 4        | SEATS   | VIRGIN P.T.F.E.  |
| 5        | O-RINGS | NBR              |
| 6        | STEM    | EXTRUDED BRASS   |
| 7        | HANDLE  | ALUMINUM         |
| 8        | SCREW   | GALVANIZED STEEL |



VALVE SEAT RATING

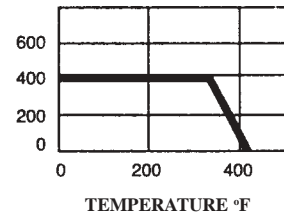

LISTED: 0.5 P.S.I.G. Tested to ANSI Z 21.15  
PRESSURE RATING: 125 W.S.P./400 W.O.G.

## SPECIFIED OPERATING AMBIENT TEMPERATURE RANGE:

-40°F to 300°F. These capacities are based on gas having a heating value of 1,000 BTU per cu. ft. and a specific gravity of 0.64 at a pressure drop of 1.0 in W.C.

DIMENSIONS IN INCHES - WEIGHT IN POUNDS

| Nominal Size | Part No. | A    | B    | C    | D    | NPT E  | BTU Capacity | Inner Box Quantity | Master Box Quantity | List Price |
|--------------|----------|------|------|------|------|--------|--------------|--------------------|---------------------|------------|
| 1/2          | 2950-05  | 2.08 | 1.30 | 0.51 | 1.15 | 1/2-14 | 290,000      | 12                 | 120                 | \$4.06     |
| 3/4          | 2950-07  | 2.54 | 1.50 | 0.59 | 1.15 | 3/4-14 | 720,000      | 12                 | 120                 | \$5.40     |

**NAPAC, Inc.**

229 Southbridge Street, Worcester, MA 01608 U.S.A.

Tel: (800) 807-2215 • Fax: (800) 807-2214