

# Forged Brass Full Port Ball Valve

## Model 2116-FT & Model 2116-FS

### 600 WOG

### ISO 9002 Certified

# UNITED BRAND

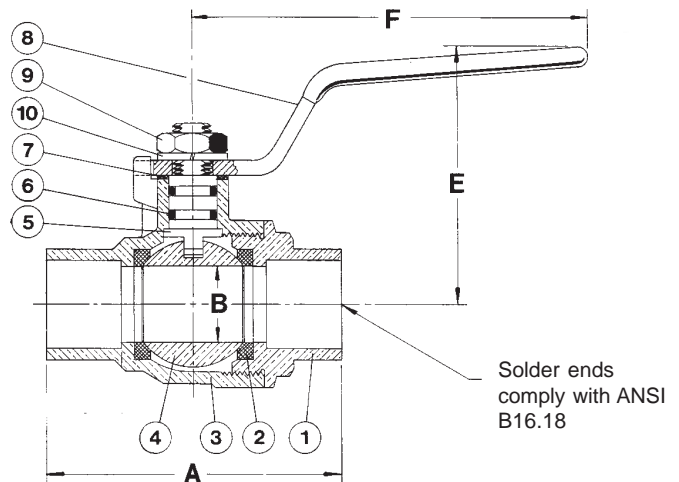
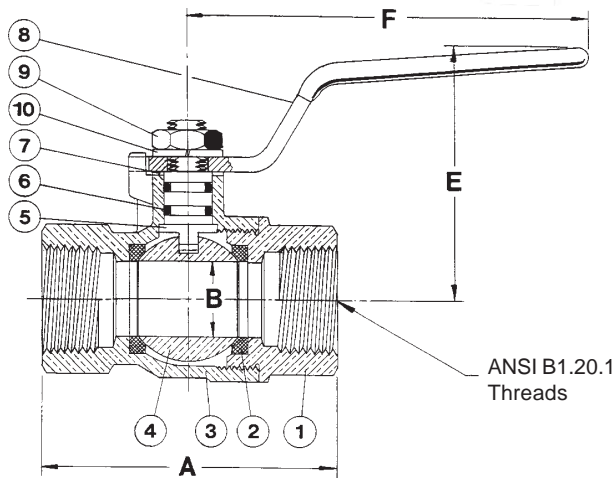

- Two Piece Hot Forged Brass Body
- Explosion Proof Stem
- Double Teflon O-Ring on Stem
- Solid Chrome Plated Brass Ball
- Virgin Teflon Seats
- UL & CSA up to 2" sizes only

SIZE	Part No. (Threaded)	Part No. (C x C)	A (Threaded)	A (C x C)	B	E	F
1/4	2116-FT-03	-	1.53	-	.24	1.65	2.36
3/8	2116-FT-04	-	1.75	-	.35	1.85	3.34
1/2	2116-FT-05	2116-FS-05	2.09	2.05	.55	2.05	3.54
3/4	2116-FT-07	2116-FS-07	2.36	2.90	.75	2.20	3.74
1	2116-FT-08	2116-FS-08	2.87	3.50	.94	2.28	4.53
1 1/4	2116-FT-09	2116-FS-09	3.38	3.90	1.22	2.70	5.51
1 1/2	2116-FT-10	2116-FS-10	3.40	4.45	1.50	3.15	5.51
2	2116-FT-11	2116-FS-11	4.23	5.25	1.93	3.54	5.90
2 1/2	2116-FT-12	-	5.51	-	2.52	4.82	8.27
3	2116-FT-13	-	6.30	-	2.95	5.10	8.27
4	2116-FT-14	-	7.43	-	3.90	6.18	10.24

Dimensions in inches

ITEM NO.	PART	QTY.	MATERIAL
1	End Cap	1	ASTM C37000
2	Seat Ring	2	P.T.F.E.
3	Body	1	ASTM C37000
4	Ball	1	ASTM C37000
5	Stem	1	ASTM C37000
6	O-Ring	2	NBR
7	Packing	1	P.T.F.E.
8	Handle	1	STEEL
9	Nut	1	
10	Lock Washer	1	BRASS

**NAPAC, Inc.**

229 Southbridge Street, Worcester, MA 01608

Tel: (800) 807-2215

Fax: (800) 807-2214